

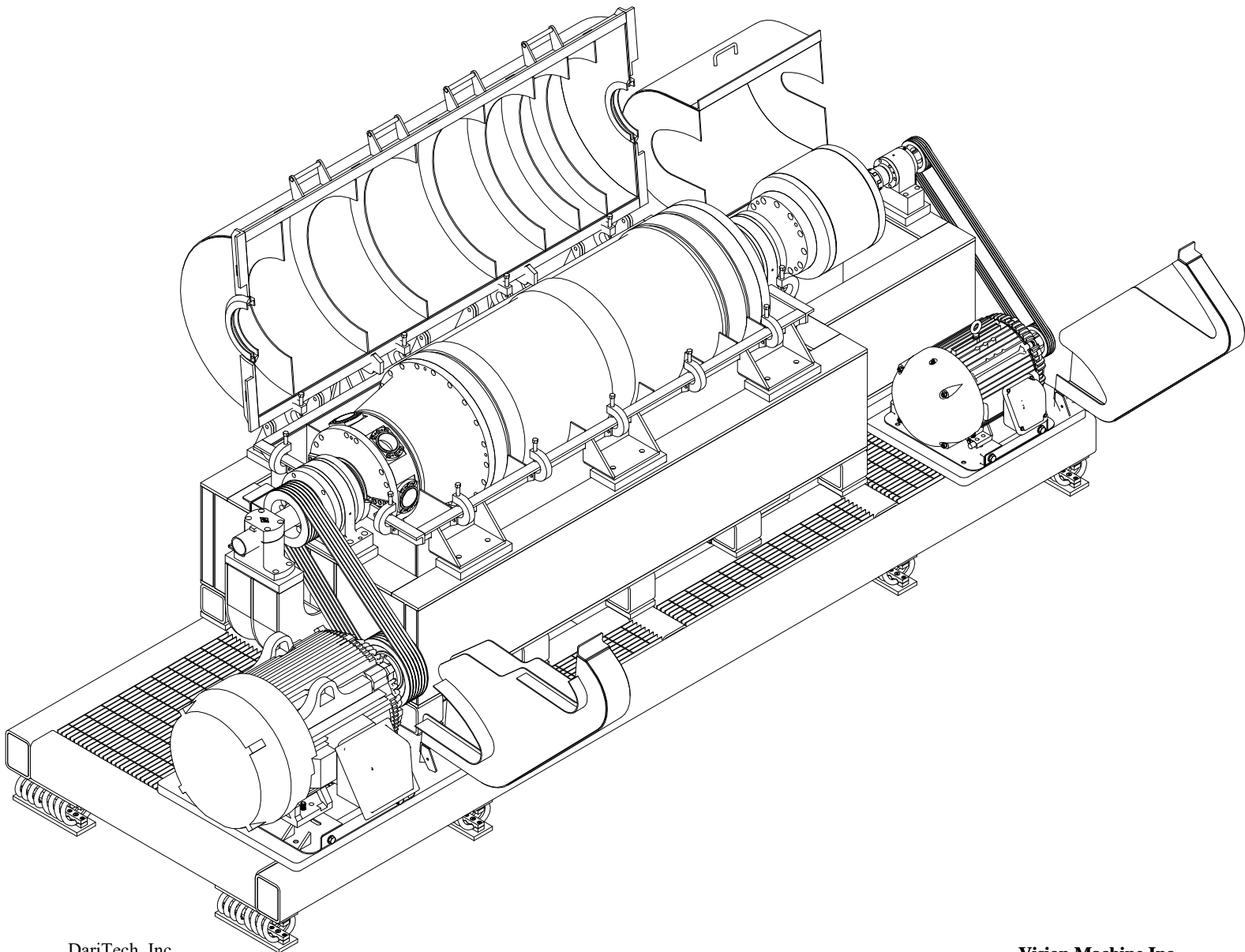

# TYPE 8 24x84 MANUAL



DariTech, Inc.  
Phone: 360-354-6900  
email: [info@daritech.com](mailto:info@daritech.com)

**Vision Machine Inc.**  
Phone: 832-562-2112  
email: [sales@visionmachine.com](mailto:sales@visionmachine.com)

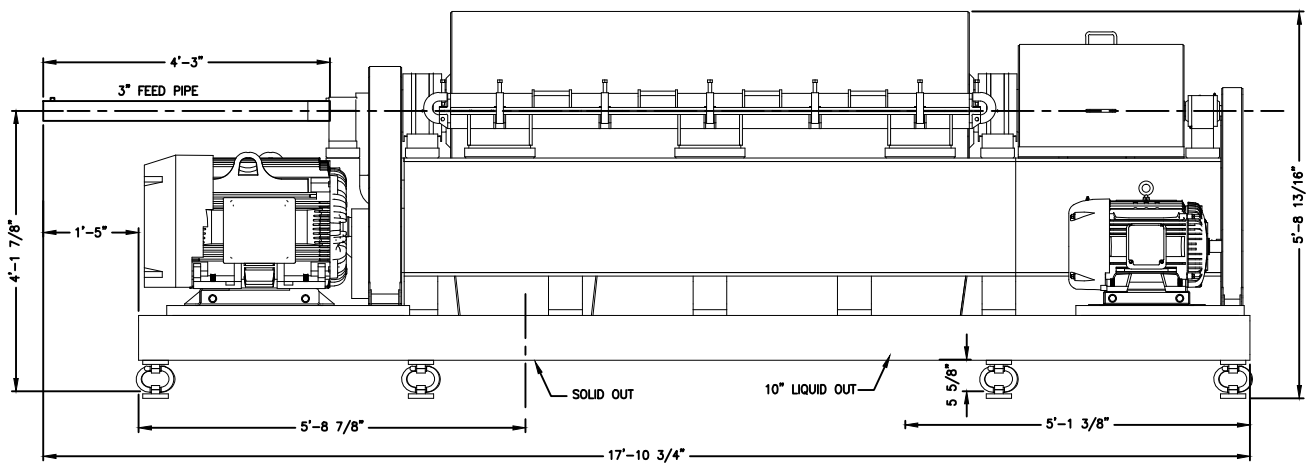
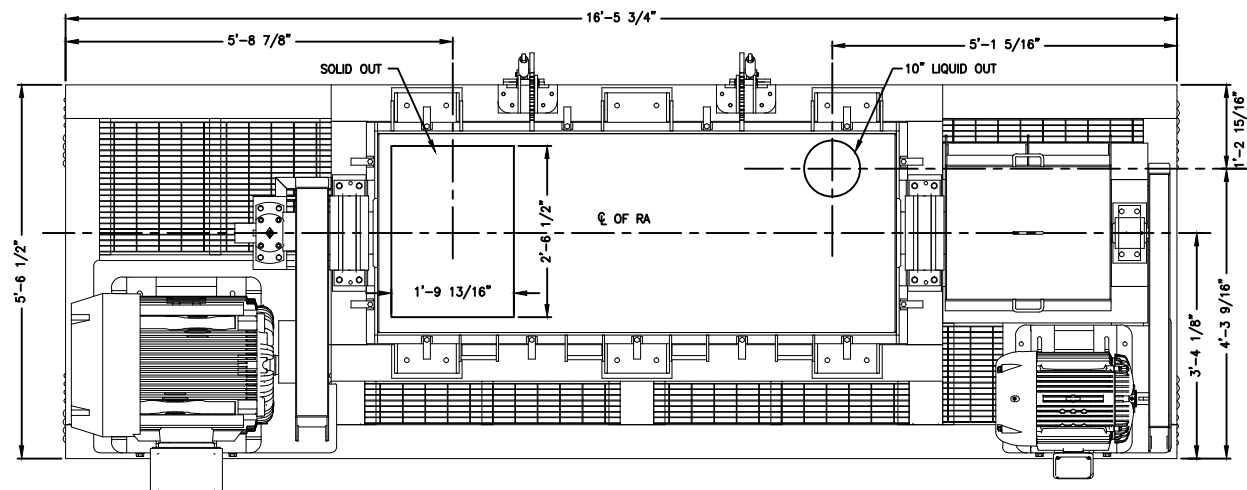
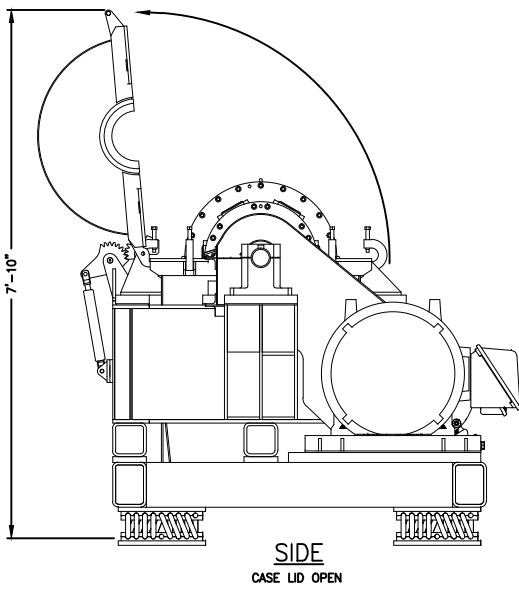

DATE	DRAWN	CHECKED	APPROVED
04/25/18	RS	RS	RS
CLIENT			
VISION MACHINE			
TITLE			
24 X 84 PRELIMINARY LAYOUT			
SCALE	NTS	SHEET	VM
DRAWING NUMBER		SHEETS	REV
VM		SH# 1 of -	0

# TYPE 8 24 x 84 SPECIFICATIONS

Inside Bowl dimensions 24" x 84"

Motor Main - 150 or 200 hp @ 1800 rpm 460 V

Motor Back Drive - 50 or 75 hp @ 1800 rpm 460 V

Gearbox - Planetary gearbox 95:1 ratio, max output torque 180,000 in/lbs

Max Pinion Input torque - 1392 in/lbs

Overall dimensions 17'-10-3/4" x 5'-6 1/2" x 7'-10" (Lid open)

Overall estimated dry weight 23,000 lbs

Machine Capacity - up to 600 gpm, depending on Freshwater through capacity

Max Bowl rpm - 3000

Normal running rpm up to - 2700

Max G Force - 3000

Power Requirement - 150 hp motor 460 Full Load Amp 172.0

200 hp motor 460 Full Load Amp 226.0

50 hp motor 460 Full Load Amp 60.0

75 hp motor 460 Full Load Amp 84.9

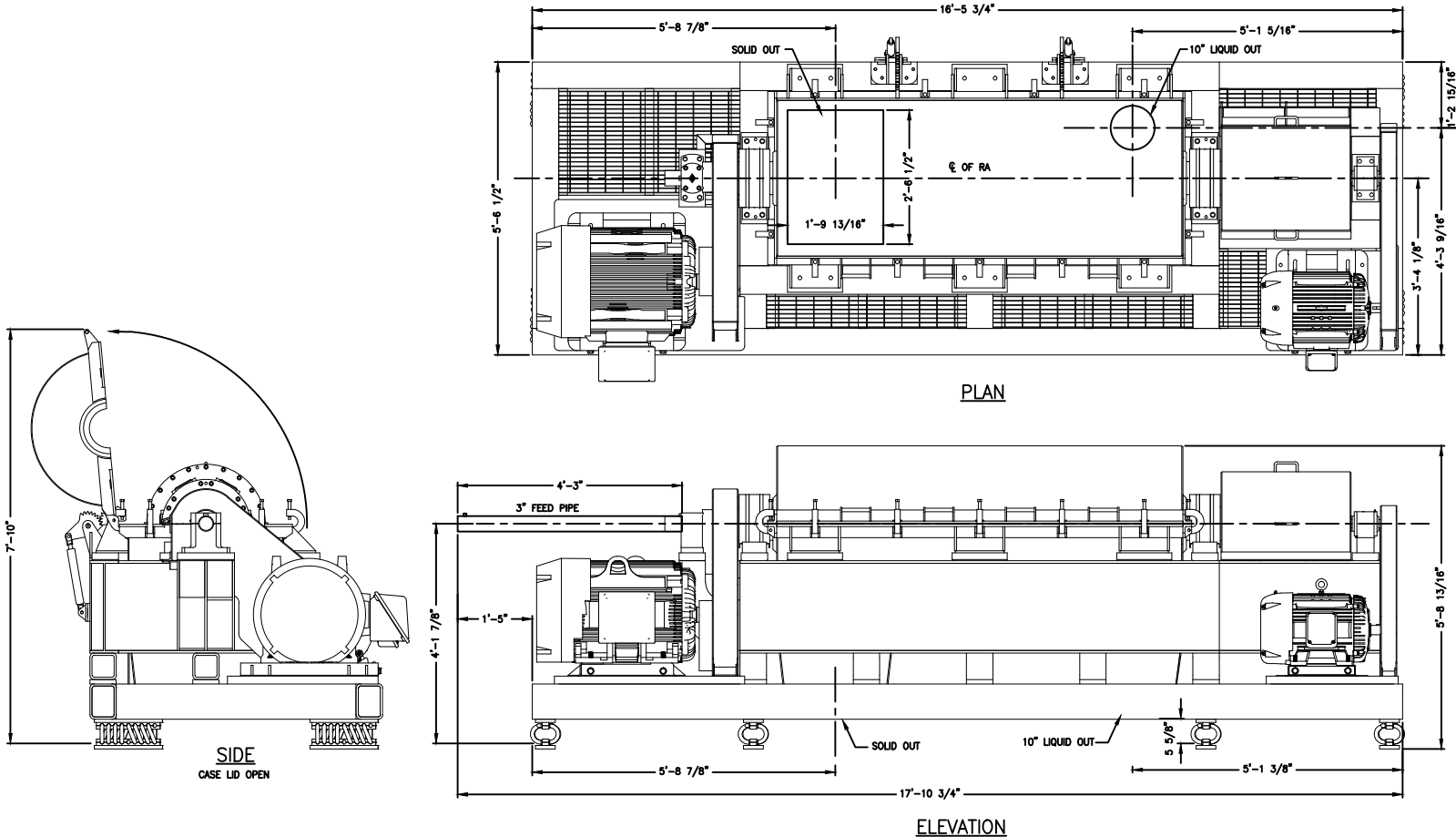

## WEEKLY MAINTENANCE

### INSPECTION POINTS

1. Main Drive belt for cracks and tension
2. Back Drive belt for cracks and tension
3. Gearbox location for oil leaks
4. Solid Head Case Wiper Plows for damage or wear
5. Conical Case Plows for damage or wear
6. Solid Discharge Nozzle for damage or wear
7. Case Wear Pad for damage or wear
8. Inspect Lovejoy Coupling Assembly

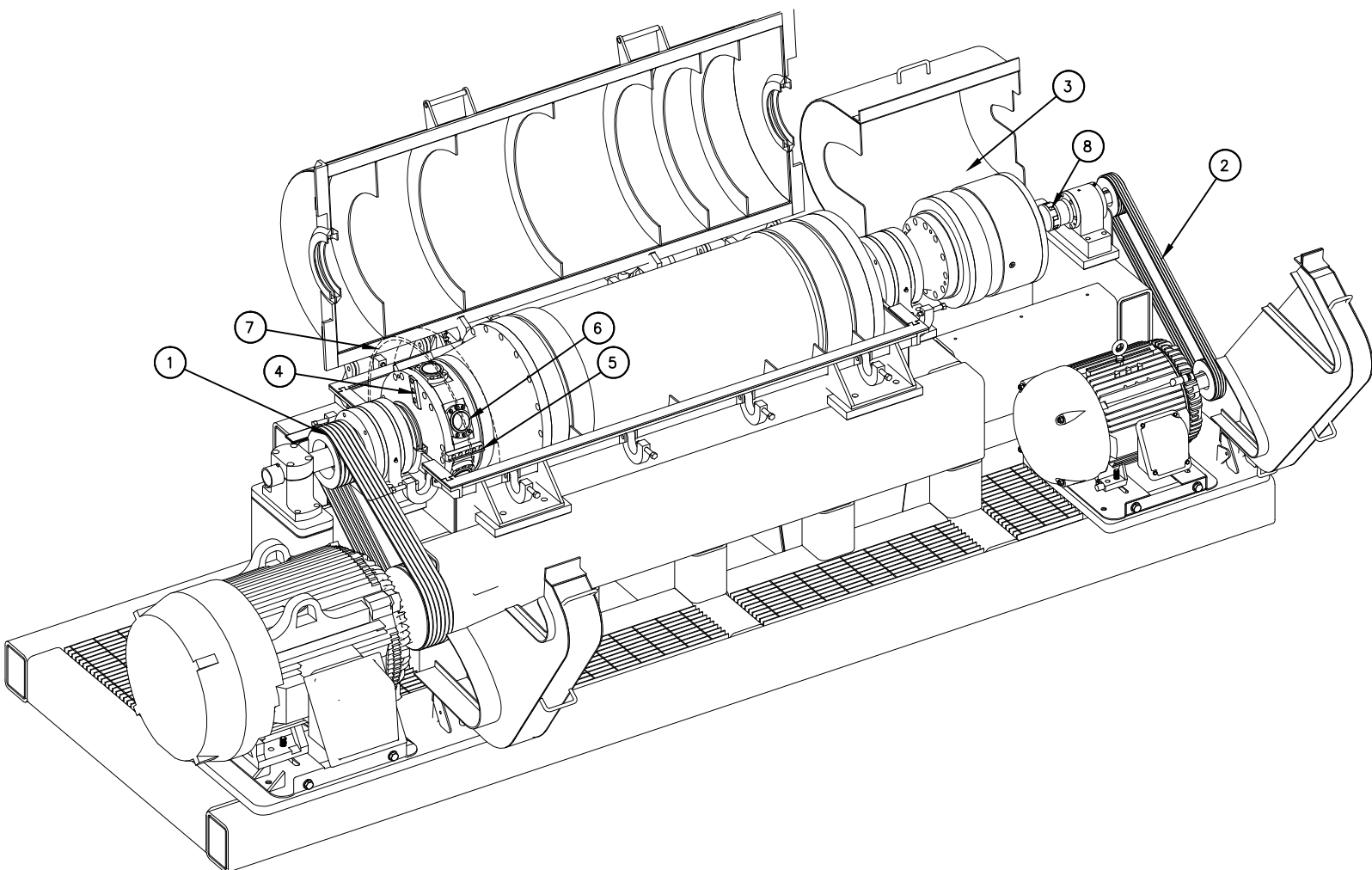

## DAILY MAINTENANCE

MAINTENANCE : Main bearings  
(Routine Maintenance)

Factory Grease Schaeffer 278 Super Polyurea

1. Main Bearing Solid end grease port locations
2. Main Bearing Liquid grease port locations

MAINTENANCE : Over Hung Load Adapter  
(Routine Maintenance)

Factory Grease Schaeffer 278 Super Polyurea

3. Over Hung Load Adapter grease port locations

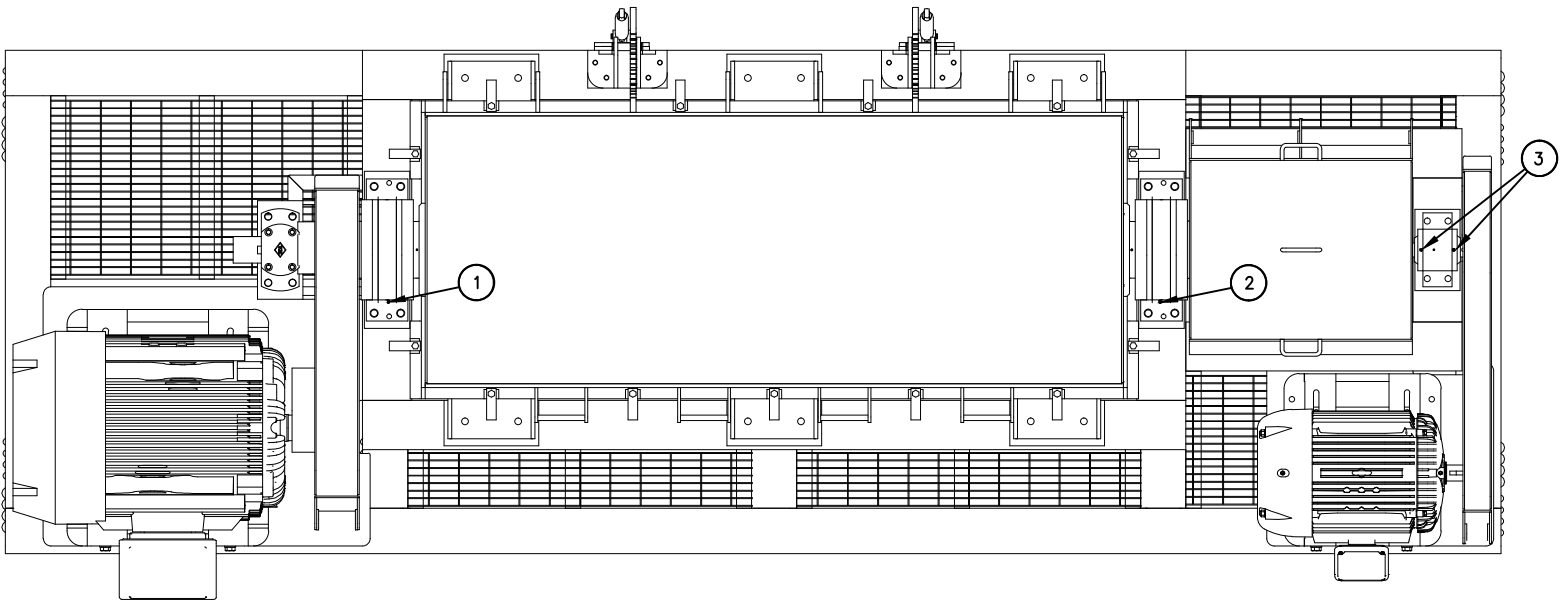

Your machine is lubricated when it leaves the factory with enough grease in main bearings and overhung load adapter to get you through the first 8 hours of operation. The conveyor bearings and gearbox are properly lubricated from factory and should be checked at first weekly service.

## WEEKLY MAINTENANCE

### MAINTENANCE : Gearbox

(Routine Maintenance and Inspection once a week while machine is off)  
Gear Oil Schaeffer 0158 Pure Synthetic Compressor Oil ISO220

#### Open Gearbox Guard

1. & 2. Gearbox Oil port locations - Turn Gearbox where fill port (1) is at 0°, Remove fill port (1) & oil level port (2) plugs, fill with Schaeffer 0158 Pure Synthetic Compressor Oil ISO220 until oil runs out of oil level port (2), reinstall plugs with teflon thread tape or paste

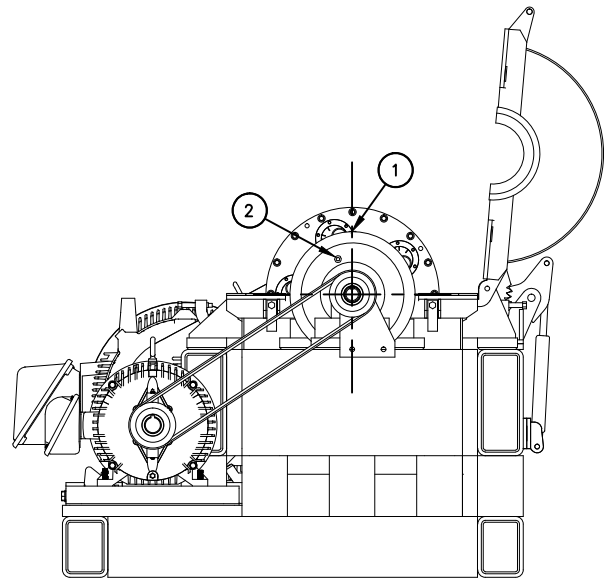
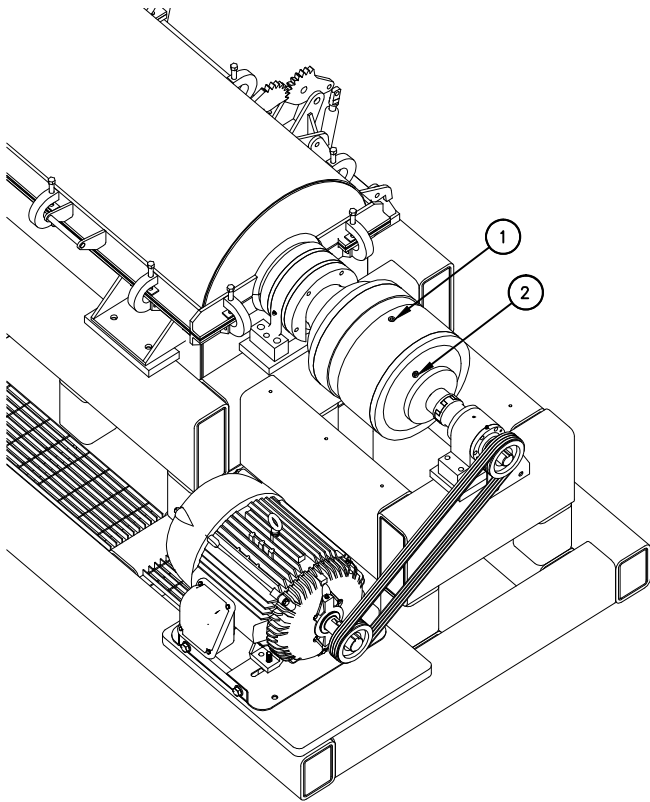

## WEEKLY MAINTENANCE

MAINTENANCE : Conveyor Liquid and Solid bearings  
(Routine Maintenance and Inspection once a week while machine is off)  
Factory Grease Schaeffer 278 Super Polyurea

### Open Case

3. & 4. - Liquid End Bearing grease port locations - remove either one of the Zerk fittings and SLOWLY\* pump grease in remaining Zerk until grease purges from open port, reinstall Zerk fitting

5. & 6. - Solid End Bearing grease port locations - remove either one of the Zerk fittings and SLOWLY\* pump grease in remaining Zerk until grease purges from open port, reinstall Zerk fitting

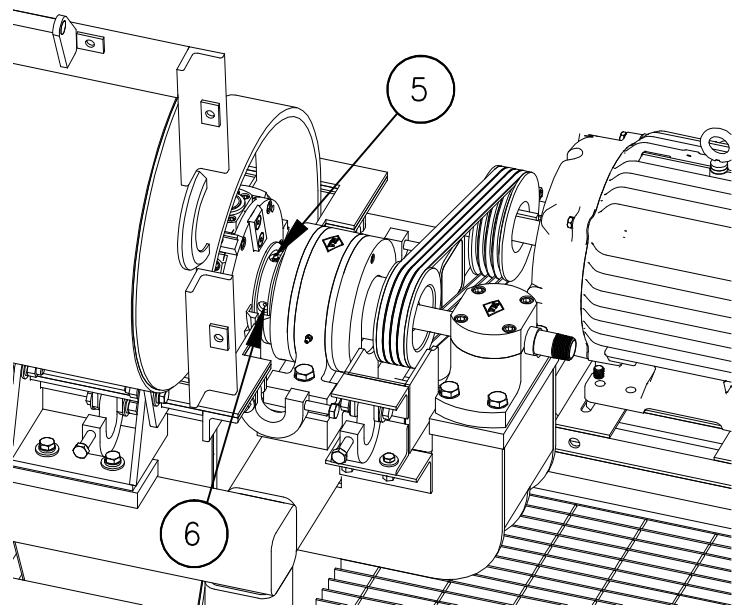
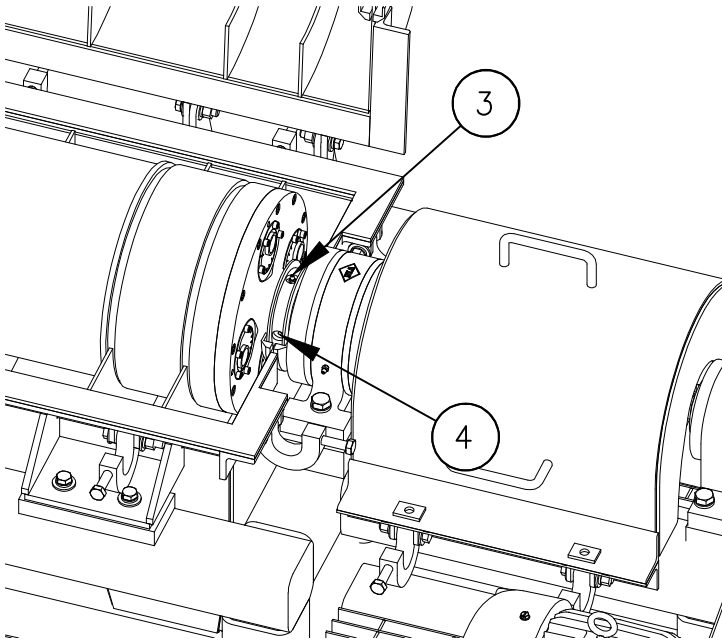

- \* It is important to note that conveyor bearings should be purged SLOWLY. The grease travels approximately 23" overall to complete purge cycle. Pumping grease too rapidly can blow conveyor seals and / or gearbox seal. For this reason we recommend that automatic grease guns not be used.

## START UP: TYPE 8 24X84

### Pre Start Check List

1. All Eccentric Orifices set to same depth
2. Belts properly tensioned
3. Both Motors tightened to base
4. Feed Pipe securely clamped
5. Both Belt Guards Clamps tightened
6. Gear Guard Clamps tightened
7. Case Clamps tightened
8. Feed Valve OFF

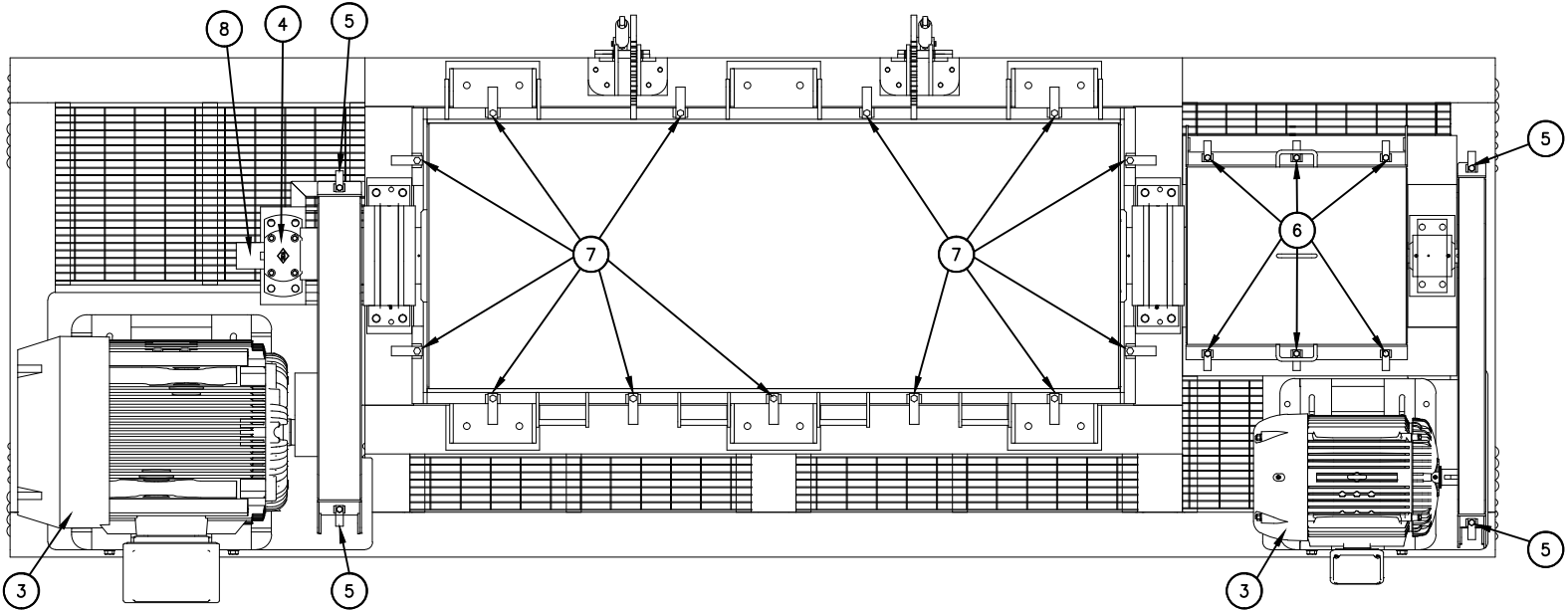
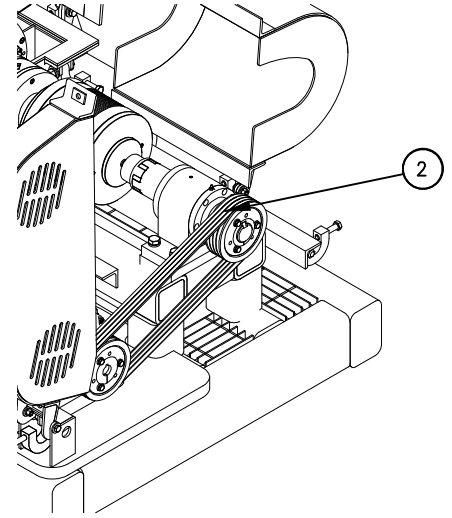
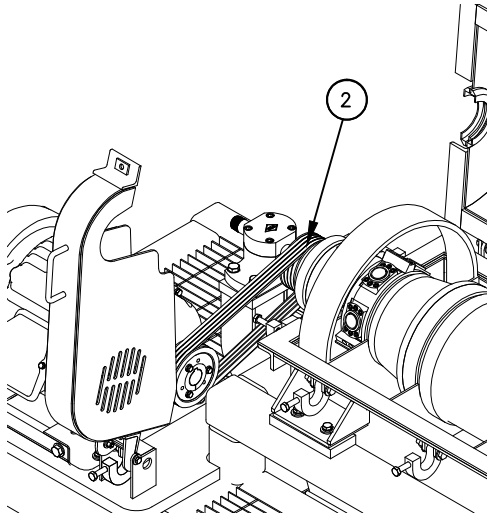
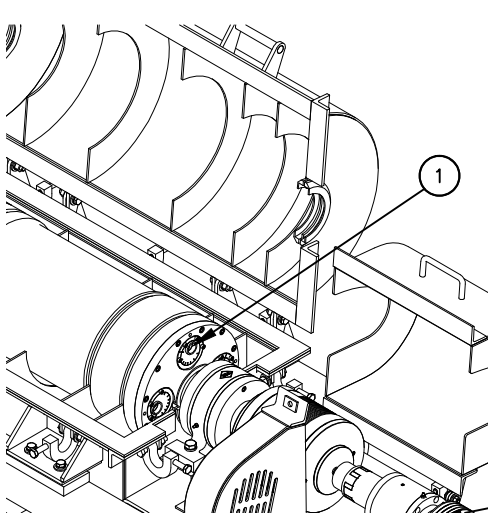



# TYPE 8 24 X 84 CONSUMABLES PARTS LIST

ITEMS	DARITECH PART NUMBERS
1. 150 HP MOTOR -----	X618
2. 50 HP MOTOR -----	R824
3. FEED PIPE -----	J176
4. MAIN DRIVE BELTS -----	E724
5. CASE PLOW -----	S246
6. CASE WIPER PLOW -----	O380
7. SOLID DISCHARGE NOZZLE -----	T327
8. WEAR PAD -----	A242
9. LOVE JOY COUPLING GREEN SPIDER --	E110
10. BACK DRIVE BELTS -----	U325
11. GEAR BACK -----	P223
12. CASE GASKET -----	O479
13. MAIN DRIVE PULLEY -----	L596
14. MAIN MOTOR PULLEY -----	A170
15. OHLA PULLEY -----	Y192
16. BACK DRIVE MOTOR PULLEY -----	Y192
17. CASE CLAMP BOLTS -----	T351
42. GUARD CLAMP BOLTS -----	M785

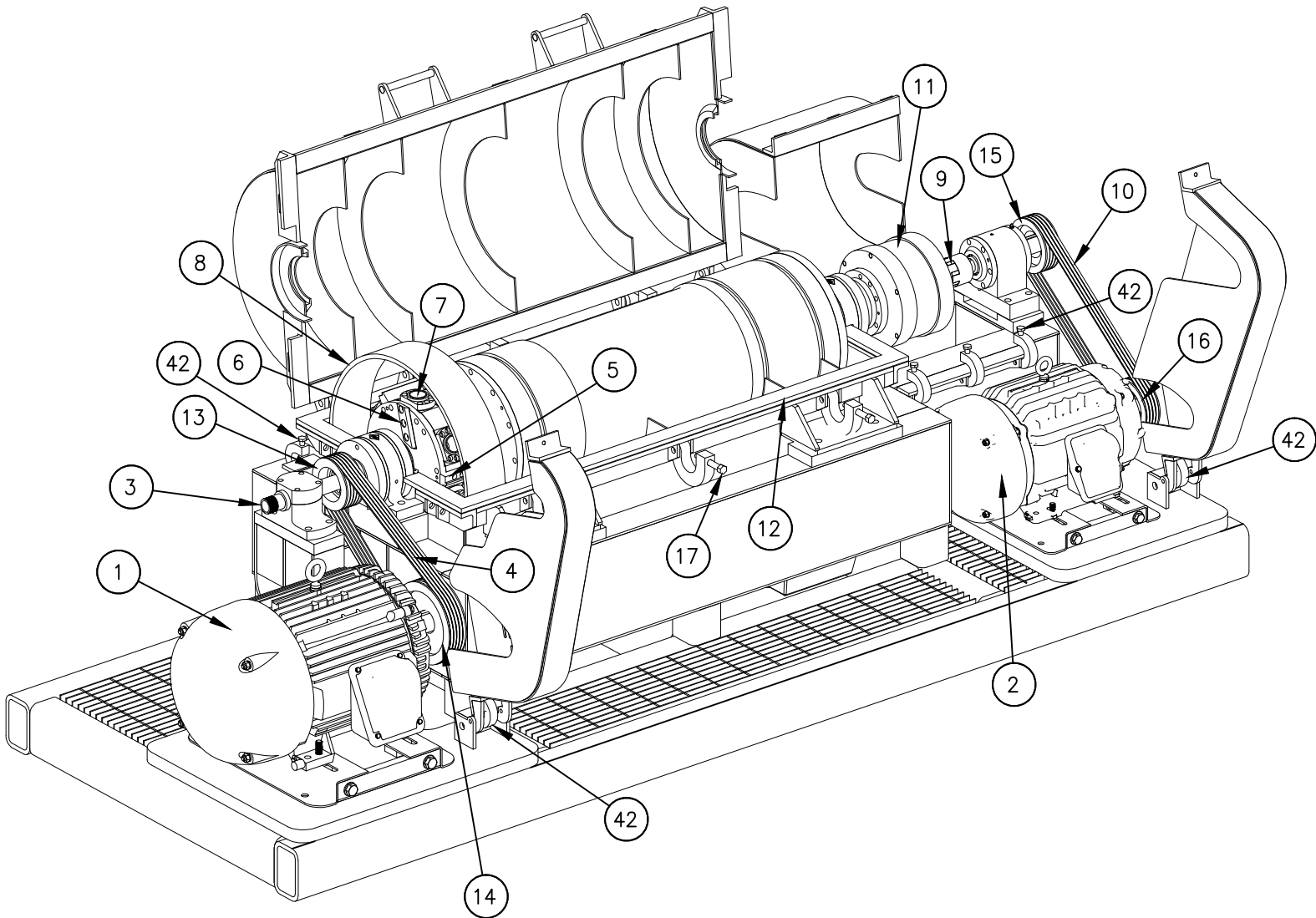

# TYPE 8 24 X 84 CONSUMABLES PARTS LIST

ITEMS	DARITECH PART NUMBERS
5. CASE PLOWS .....	S246
6. CASE WIPER PLOWS .....	O380
7. SOLID DISCHARGE NOZZLES .....	T327
9. LOVE JOY COUPLING GREEN SPIDER ----	E110
11. GEAR BOX .....	P223
13. MAIN DRIVE PULLEY .....	L596
18. CONICAL .....	C776
19. SOLID DISCHARGE RETAINER .....	C586
20. SOLID HEAD .....	U891
21. CASE FLINGER .....	Z519
22. HORSESHOE COVER .....	M311
23. GREASE FLINGER .....	R598
24. SOLID END MAIN BEARING .....	Q128
25. LIQUID END MAIN BEARING .....	R737
26. PILLOW BLOCK COVER .....	U772
27. PILLOW BLOCK .....	F342
28. LIQUID HEAD .....	O622
29. EPICENTRIC ORIFICE RETAINER .....	G787
30. EPICENTRIC ORIFICE .....	S380
31. SPLINE SHAFT .....	T450
32. GEAR FLANGE .....	W405
33. COUPLING GEAR BOX SIDE .....	B843
34. COUPLING OHLA SIDE .....	B843
35. OHLA SEALS .....	Q576
36. OHLA THRUST BEARINGS .....	L551
37. OHLA PILOT BEARING .....	L384
38. OHLA LOCK WASHER .....	V446
39. OHLA LOCK NUT .....	M425
40. OHLA CAP INBOARD .....	A761
41. OHLA CAP OUTBOARD .....	W733
43. DOWEL PINS & SLEEVE .....	F644

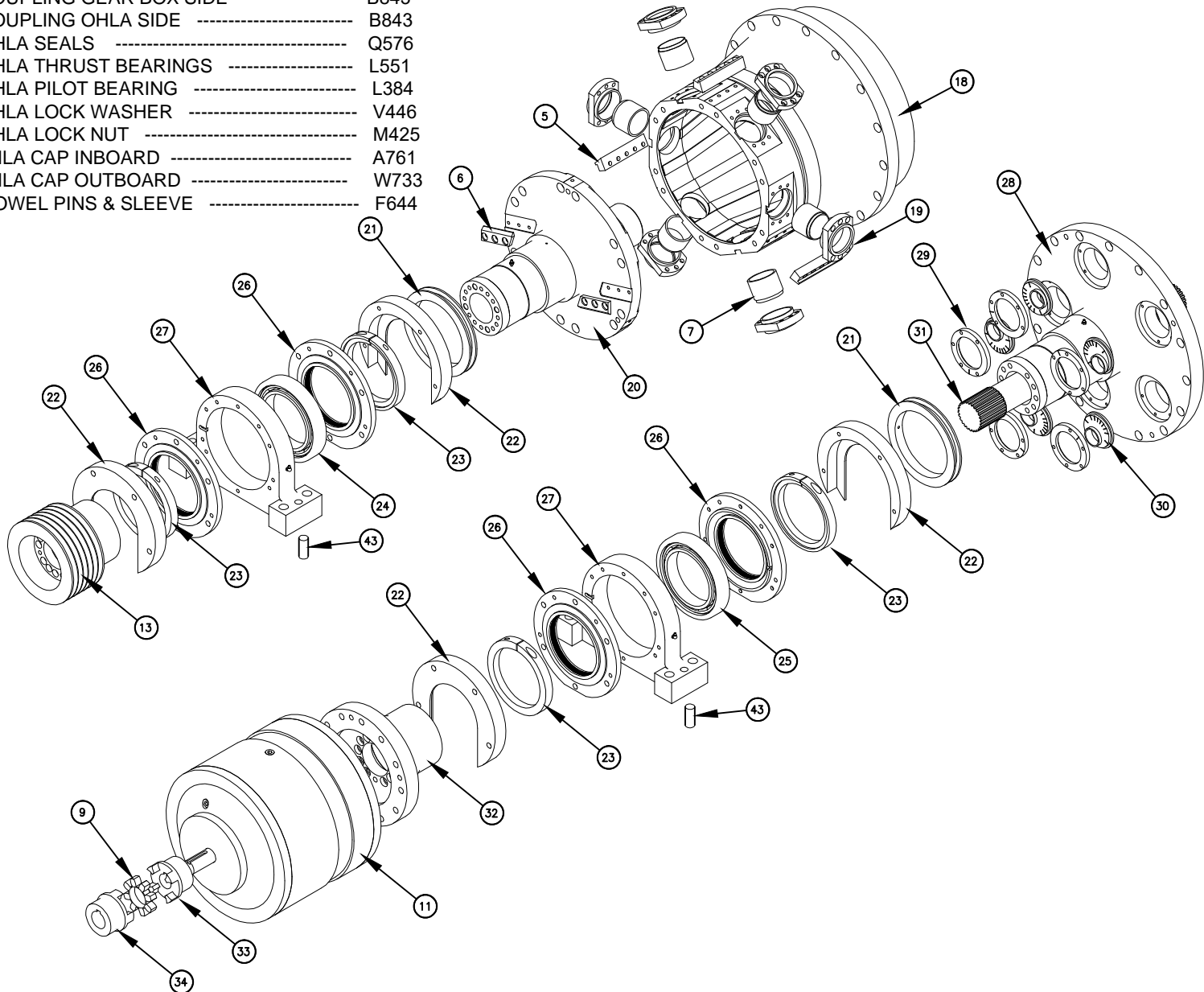
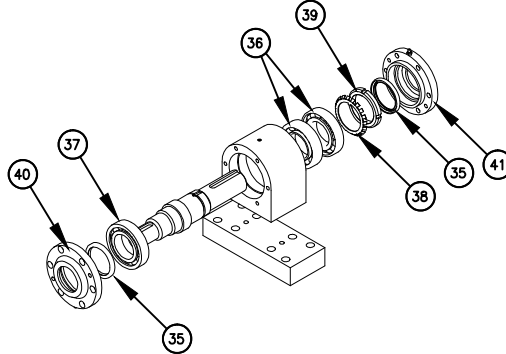



## Centrifuge Operation and Greasing Procedures

Note that some of the statements made in this document are general guidelines that work in most cases. They are not all statements of fact and in some cases may not be accurate or valid.

### Bowl RPM

- Bowl should be run at slowest RPM possible to achieve the desired results
- Faster bowl RPM means shorter bearing life and more wear, maintenance and consumable costs on machine
- In most cases, the faster the bowl RPM the drier the solids will be and the cleaner the effluent will be. Conversely, slower bowl RPM will give you wetter solids and dirtier liquids

### Backdrive RPM & Differential Speed

- Differential speed is the difference in RPM between bowl and conveyor and is also referred to as rake speed, delta speed or conveyor speed
- Backdrive motor controls conveyor to bowl differential RPM
- All Vision Machine, Inc. centrifuges utilize lagging conveyor design. That is to say the conveyor is always turning slower than the bowl when operating
- Formulas to determine differential speed
  - Forward direction (same rotation as bowl)
    - $(\text{Bowl RPM} - \text{Backdrive RPM}) / \text{Gearbox ratio} = \text{Differential Speed}$
  - Reverse direction (opposite rotation to bowl)
    - $(\text{Bowl RPM} + \text{Backdrive RPM}) / \text{Gearbox ratio} = \text{Differential Speed}$
  - Example #1
    - Bowl running 3500 RPM, backdrive running 1800 RPM in **forward** and gearbox ratio of 76:1
    - $(3500 - 1800) / 76 = 22.37 \text{ RPM differential speed}$
  - Example #2
    - Bowl running 2500 RPM, backdrive running 1000 RPM in **reverse** and gearbox ratio of 76:1
    - $(2500 + 1000) / 76 = 46.05 \text{ RPM differential speed}$
- Backdrive differential controls the conveyor speed *in relation to the bowl*, not to ground
- In forward direction, the faster you run the backdrive motor the slower the conveyor turns in relation to bowl
- In reverse direction (opposite rotation to bowl), the faster you run the backdrive motor the faster the conveyor turns in relation to bowl



- In general terms, the faster the differential RPM, the wetter the solids will be and the slower the differential RPM, the drier the solids will be

### **Pool Depth**

- Pool depth refers to the column of water in the bowl when measured from ID of bowl towards center
- On all Vision Machine, Inc. centrifuges, 1 is shallowest pool depth setting. Each subsequent number is an incrementally deeper amount even though the numbers are not evenly spaced around effluent port. For example, 2 may be 1/8" deeper than 1, 3 will be 1/8" deeper than 2, etc.
- Deeper pool depths give cleaner effluent and wetter solids
- Shallower pool depths give drier solids and dirtier effluent
- As a general rule, deeper pool depths demand less torque on gearbox
- Deeper pool depths reduce wear on machine in most applications
- Deeper pool depths allow for more product retention time

### **Feed Rate and GPM**

- Do not slug machine with product. Increase feed rate slowly until ramped up to desired feed rate
- Feed rate affects centrifuge output. Simply put, you should not expect the same results at 100 GPM that you experienced at 50 GPM
- Fluid properties such as viscosity and solids content will vary the throughput a machine can handle. Just because a machine can handle 100 GPM of fresh water does not necessarily mean it will take 100 GPM of all products
- Higher feed rates will usually give you dirtier effluent and wetter solids due to decreased product retention time in bowl
- Higher feed rates increase wear and tear and maintenance
- Feed limiting parameters are
  - Main drive motor has reached full load amps
  - Backdrive has reached torque trip point
  - Product burping or spraying or misting out around feed tube
  - Spillover point has been reached. Spillover is defined as water is coming out of solids end of machine after wall cake has been established
- It is not recommended to operate machine at maximum feed limits as this greatly increases wear and subsequent maintenance costs. Vision Machine, Inc. recommends operating machine at around 60 - 75% of max feed when throughput is most important variable



## Main Bearing Lubrication

- **This is a set of guidelines for greasing bearings, not set in stone rules.** The bearing manufacturer has provided replenishment rates based on operating conditions that do not work for a decanter centrifuge application. However, we have had great success running our bearings on grease. Main bearing lubrication should be thought of as a dynamic and evolving procedure. Your circumstance may, and probably will, be different from any other application and will have to be adapted to your exact operating parameters
- There is no “normal” operating temperature range
- RPM, ambient temperature, process fluid temperature, belt tension, bearing alignment and other factors all play a role in “normal” running temperature and lubrication frequency
- “Normal” bearing temperature is usually somewhere between ambient temperature and 50-degrees above ambient
- Bearings should never be operated above 185-degrees Fahrenheit
- **Main bearings should be given approximately one shot of grease, from standard hand pumped grease gun, for every 8 hours of operation time**
- Grease should be pumped in slowly
- Bearing temperature should be measured on the surface of the main bearing pillow block over Vision Machine logo or with controls provided when centrifuge was purchased
- **DO NOT PUMP MORE THAN 5 SHOTS OF GREASE PER BEARING AT ANY ONE TIME. EVER.** Excess grease can cause bearing failure faster than too little grease
- **Regarding temperature** - Give main bearing one shot of grease
  - If bearing cools down after greasing, your **bearing was starving for grease.**
    - If this occurs, wait one hour and give one more shot of grease. Repeat this procedure until bearing temperature rises slightly and then cools back down to “normal”
  - If bearing heats up after greasing, **this is normal** and your bearing has the appropriate amount of grease. Allow machine to continue to operate and the temperature will gradually come back down to “normal” operating temperature. Cool down may take up to several hours
  - If bearing heats up after greasing and does not come back down to “normal” within 5 hours or reaches 185-degrees F, your **bearing has too much grease**
    - If bearing does not cool down to “normal” within 5 hours but stays below 185-degrees F, skip next scheduled greasing

If bearing reaches 185-degrees F, simply shut down machine and allow bearing to cool down for approximately one hour. Re-start machine and



- most frequently, but not always, bearing will heat up again and gradually come back to “normal”
- If bearing exceeds 185-degrees F again after shutting down and allowing to cool off, your **bearing still has too much grease**. Shut down again, allow to cool off and re-start. This process may need to be repeated several times but rarely more than 3 times
- **When in doubt, err to the side of ONE additional shot of grease**. It is better to add a little too much grease and heat up the bearing slightly than to starve the bearing for lubrication and cause premature failure

#### **Conveyor Bearing Lubrication**

- Conveyor bearings should be purged **once per week**
- If machine is equipped with purge hole plugs, remove plugs and SLOWLY pump grease into fitting until clean grease purges out of port. Repeat process on solids end and liquid end of machine
  - DO NOT USE AUTOMATIC GREASE GUN as this will blow out the conveyor seals
  - Take note of contaminated grease. This is an indication that seals have been compromised and will lead to conveyor bearing failure
  - Solids end conveyor bearing usually takes less grease to purge than liquid end conveyor bearings

#### **Overhung Load Adapter Lubrication**

- OHLA should be given 3 - 5 shots of grease **once per week**
- **Regarding temperature**, same rules apply as when greasing main bearings

#### **Operational Guidelines**

- **For Drier Solids**
  - Slow down differential RPM
    - Trade-off is increased torque
  - Change pool depth to shallower setting
    - Trade-off is increased torque and dirtier effluent
  - Decrease feed rate
    - Trade-off is less fluid processed
  - Increase bowl RPM
    - Trade-off is more maintenance and associated costs and shorter duration between major repairs



➤ **For Cleaner Effluent**

- Change pool depth to deeper setting
  - Trade-off is wetter solids
- Decrease feed rate
  - Trade-off is less fluid processed
- Increase bowl RPM
  - Trade-off is more maintenance and associated costs and shorter duration between major repairs

➤ **To decrease backdrive torque**

- Speed up differential RPM
  - Trade-off is wetter solids
- Decrease bowl RPM
  - Trade-off is wetter solids and dirtier effluent
- Decrease feed rate
  - Trade-off is less fluid processed

➤ **To decrease main drive load**

- Change pool depth to deeper setting
  - Trade-off is wetter solids
- Decrease feed rate
  - Trade-off is less fluid processed
- Decrease bowl RPM
  - Trade-off is wetter solids and dirtier effluent



DariTech, Inc.  
Phone: 360-354-6900  
email: [info@daritech.com](mailto:info@daritech.com)

Vision Machine Inc.  
Phone: 832-562-2112  
email: [sales@visionmachine.com](mailto:sales@visionmachine.com)

