



**DTX 24" Model**



**DTX 48" Model**



**DTX 96" Model**

# The **DTX**

by DARITECH

DariTech, Inc., continues to lead the way with the expansion of the DTX line of separators.

Offering three sizes to fit the industries dairy needs with six screen opening sizes to match the system requirements.

The DTX separator allows for fine separation without the screen cleaning. Also allows for high throughput without the need to manage feed rates even with high dissolved manure solids content.



Manufactured in the USA

## DTX 24" Model

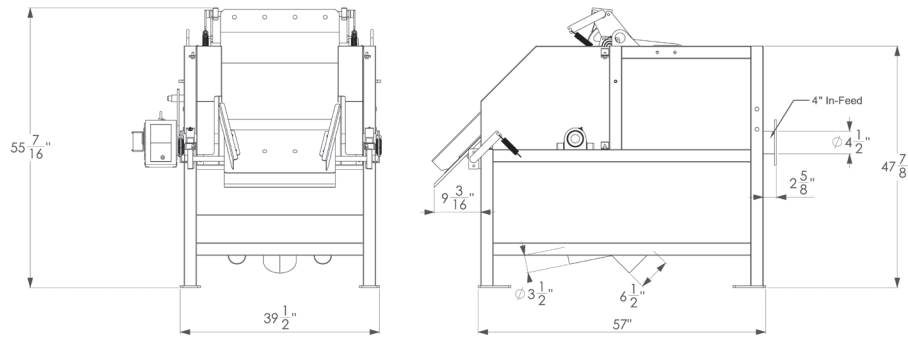

## DTX 48" Model

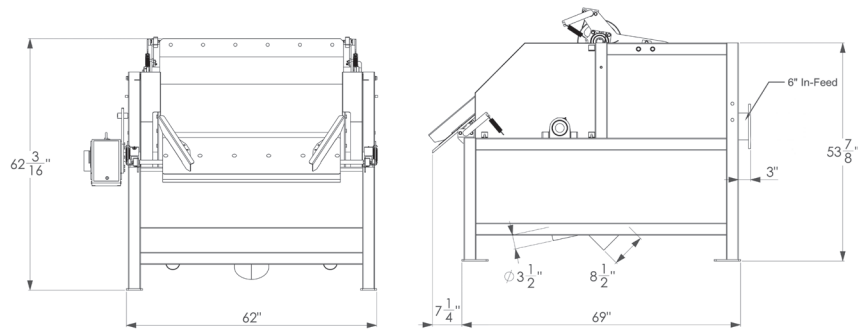

## DTX 96" Model

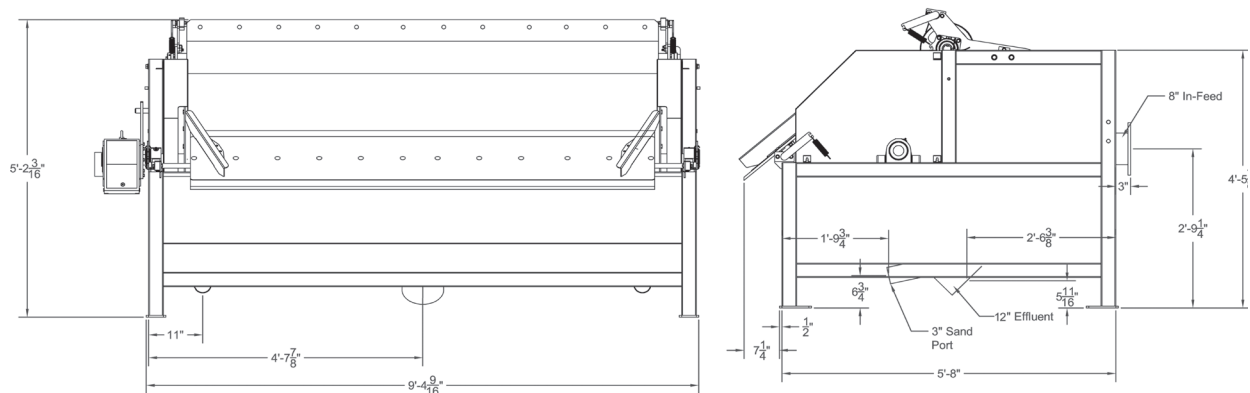

## Roller Presses



22" 4 Roller



42" 4 Roller



34" 2 Roller (weighted)



34", 48", 72" & 96" 2 Roller





With the introduction of the wedge wire screens in all model sizes, each model can be configured for standard separation, bedding or high capture separation. With high capture separation, a fine screen can be used for closed loop flush, flush flume systems, secondary separation, or high capture primary separation.



“The capacity we had with our side hill was not enough to keep up with our flush. After we put in the DTX and DariTech’s process system, our runtime is greatly reduced and our capture rate tripled”

“The DTX has allowed us to add alley vac manure to our flush system without having to manage and clean our separators.”

Built in bypass



Manure pulling through a screen







**Features:**

- Adaptable to multiple roller presses
- Parts available same day or next day delivery
- High performance machine design
- Direct drive, no wheels, gears or chains, eliminates wear and repairs
- Integrated bypass for varying feed routes
- Built in rock trap
- Operation not effected by change in feed consistency
- Corrosion resistant
- Low horsepower
- Field serviceable
- Small footprint
- Easy to operate and maintain



Daritech, Inc • Lynden, WA

**Why Daritech?**

Daritech is the most complete manure separation company in the industry, with separators and systems for any animal feeding operation. Always focused on low operating and maintenance costs, Daritech brings the best value to your operation.



**Daritech, Inc**  
8540 Benson Road  
Lynden, WA 98264  
Toll Free: 800-701-3632  
Phone: 360-354-6900